

			Datum						=
			Bearb.	MOL					+0
			Gepr.	14.03.2002					
Anderung	Datum	Name	Norm		Urspr.	Ers. f.	Ers. d.		
								306 703-245	B1. 20 20 B1.

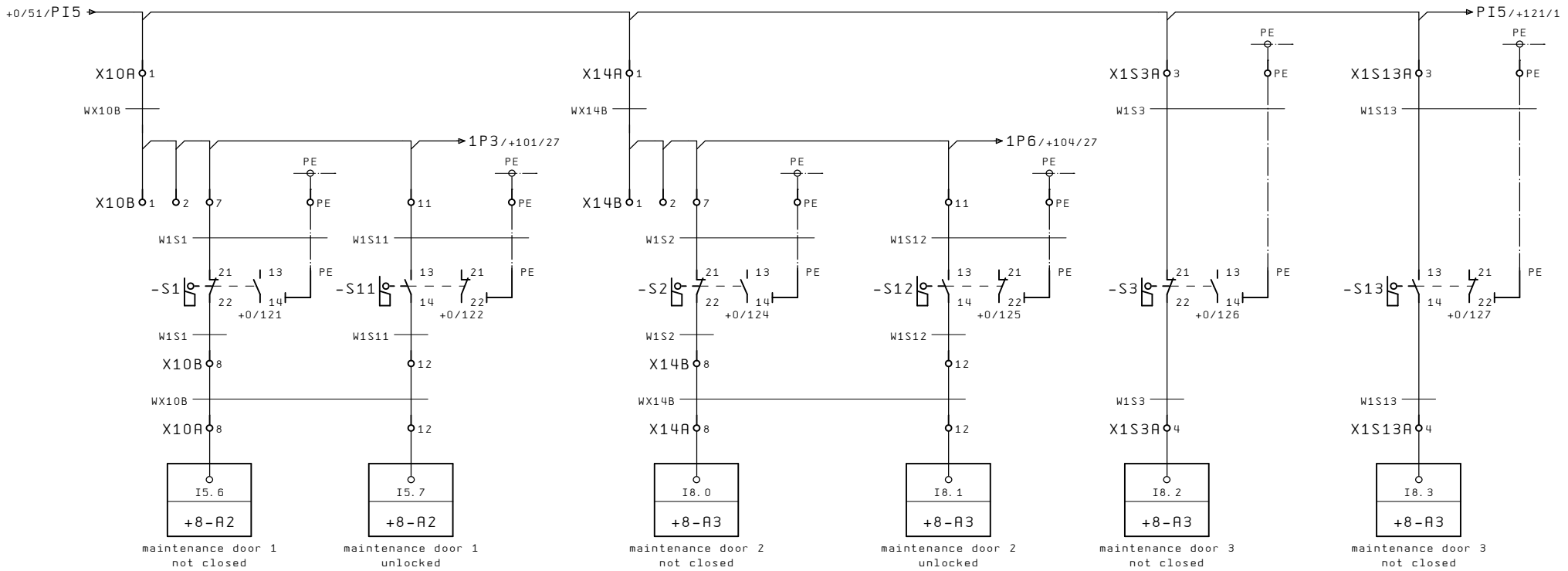

maintenance door interlock

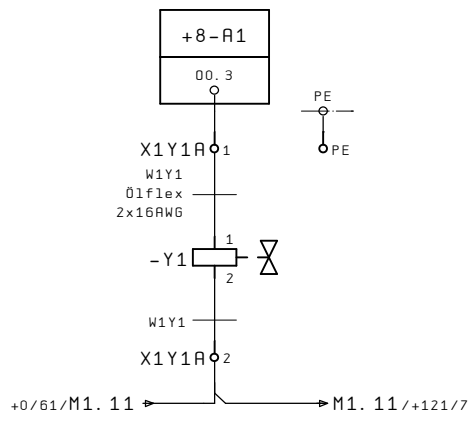

				Datum								=
				Bearb.	MOL						+1	
				Gepr.	14.03.2002							
Anderung	Datum	Name	Norm	Urspr.	Ers. f.	Ers. d.					B1. 1	
											306 703-245	1 Bl.
												1 Bl.

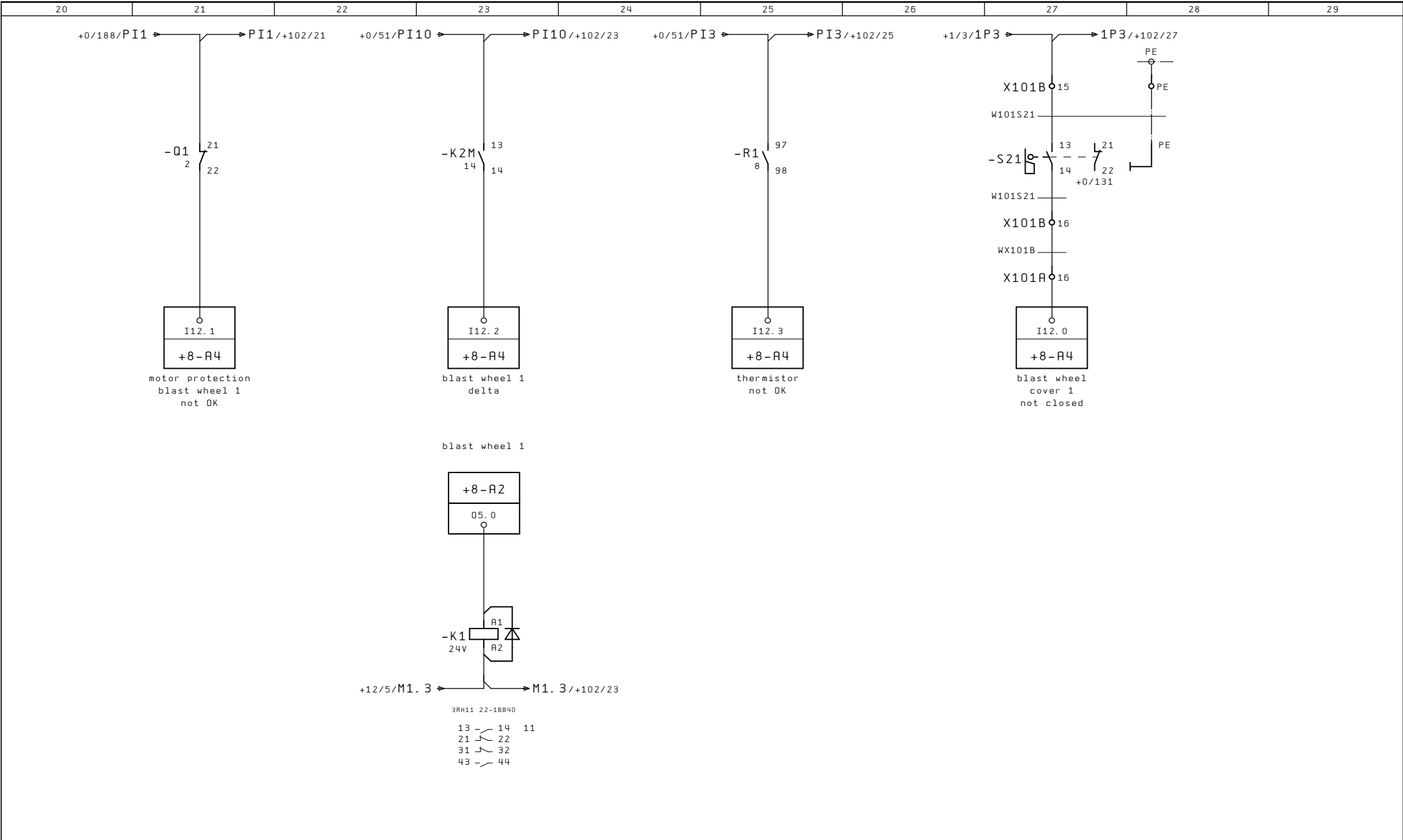

Datum				=				
Bearb. MOL				+101				
Gepr. 14.03.2002							B1. 3	
Anderung	Datum	Name	Norm	Urspr.	Ers. f.	Ers. d.	3 B1.	